

## SECTION "A-A"

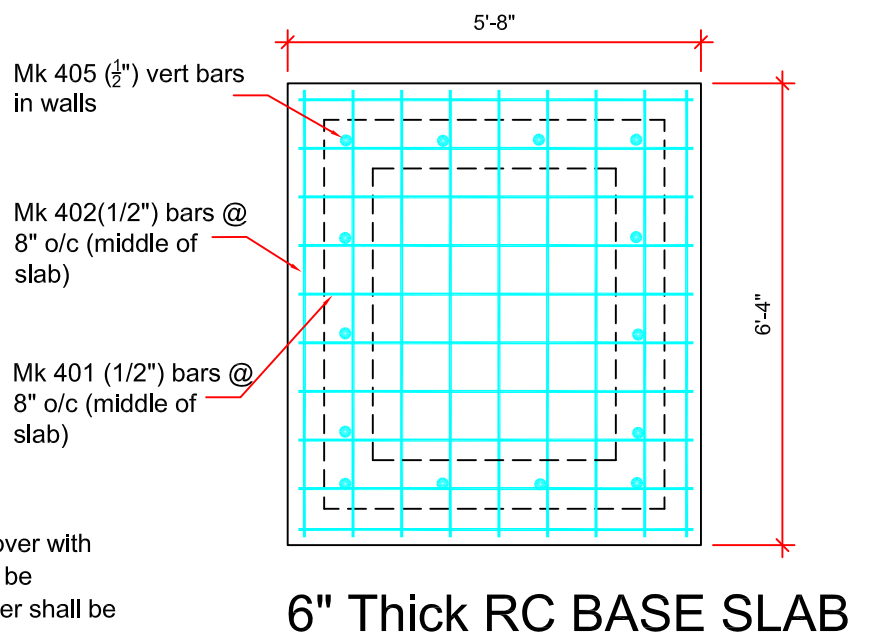
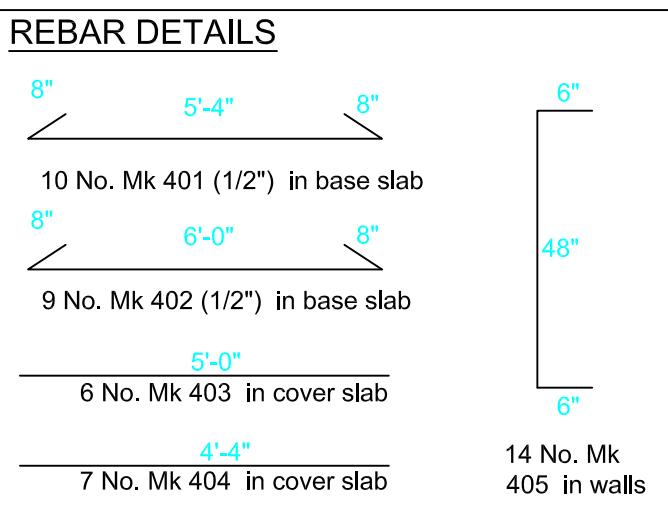
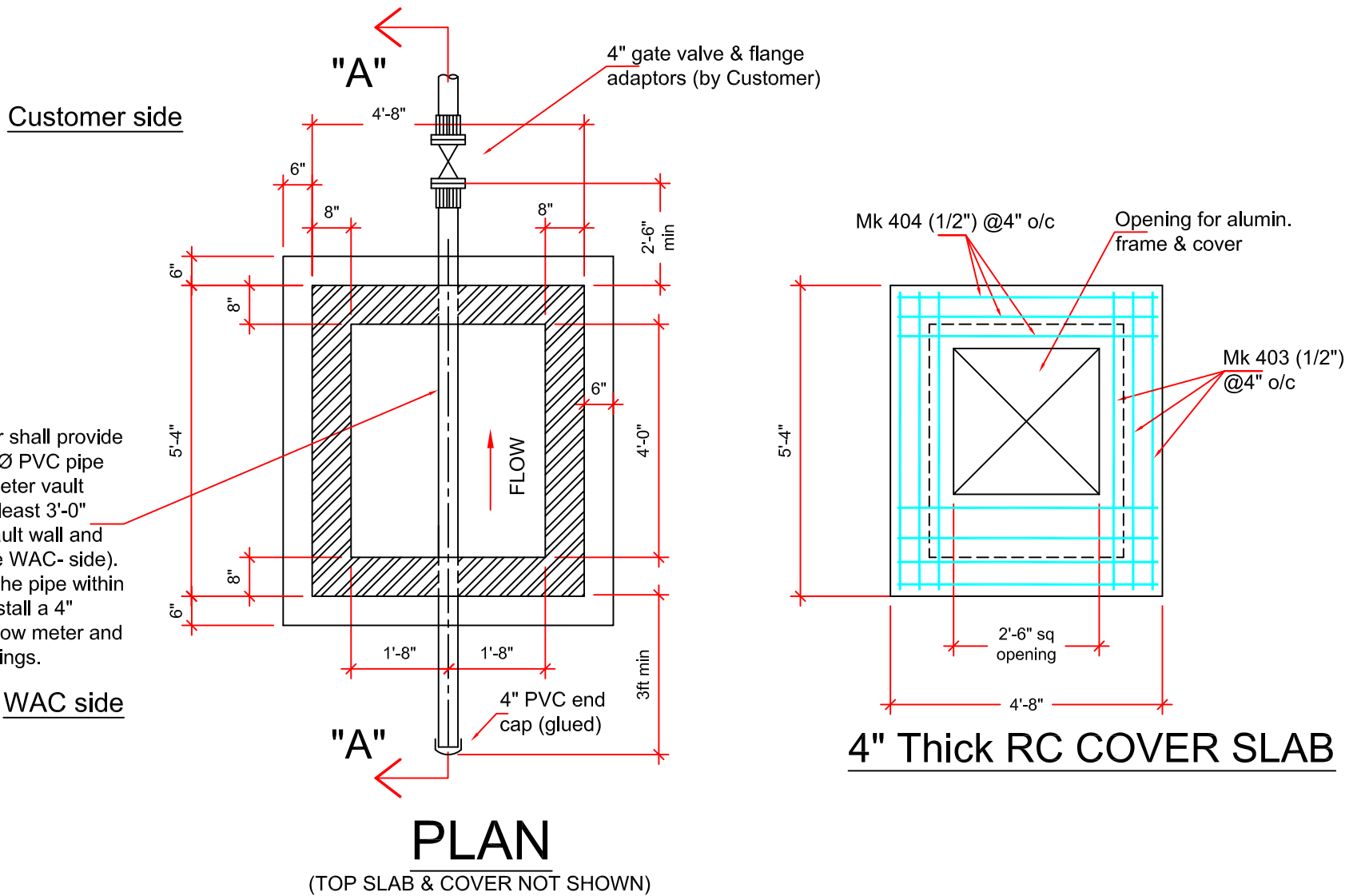

### NOTES

- The vault's access cover shall be an aluminum, slip resistant, solid top, hinged cover with upstanding frame, incorporating safety stay and staple for padlocking (padlock to be supplied by Water Authority). Minimum clear opening shall be 30" X 30". The cover shall be designed to withstand 0.5 tonnes test loading, non-vehicular traffic.
- On completion, the meter vault shall be tested for water tightness in accordance with Section 11 of the Water Authority's "Guidelines for Constructing Potable Water Mains"

**WATER AUTHORITY - CAYMAN**

STANDARD 4" WATER METER VAULT  
CUSTOMER DETAILS



WATER AUTHORITY - CAYMAN  
P.O. BOX 1104, GT  
CAYMAN ISLANDS  
345-949-6352

### REVISIONS

REV	DATE	BY	DESCRIPTION
5	Aug 2018	CJG	4" pipe thru' chamber to be capped
4	Aug 2011	CJG	Chamber extended to fit Z-strainer
3	Feb 2008	CJG	Notes Amended
2	Nov 2005	CJG	Notes Amended
1	3/2/05	TVZ	Notes Revised

DATE: 28/5/02  
DRAWN BY: GL  
CHECKED: CHKD\_BY  
PROJECT NO.  
PROJ. NO.

WAC PROJECT NO.  
P40  
DRAWING NO.  
C-30  
SCALE  
VIEW  
SHEET  
REV  
5